

Carest Charging module for rechargeable battery ACM1803B

The charging module is designed for charging single-cell lithium-ion (LiON) batteries.

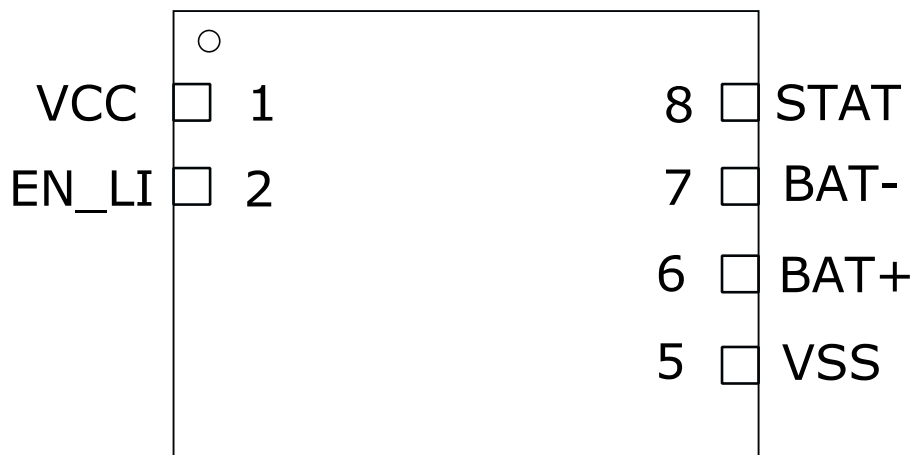

Pic.1 Schematic view ACM1803B.

Table 1. Contact overview ACM1803B:

PIN		Input/Output	Description
NAME	NUMBER		
VCC	1	Input	Supply voltage. Connects directly to the positive terminal of the charge source.
EN_LI	2	Input	Switch on the charging of the Li-Ion battery.
VSS	5	Input	GND. Connects directly to the negative terminal of the charge source.
BAT+	6	Input	Positive battery terminal.
BAT-	7	Input	Negative battery terminal.
STAT	8	Output	Charge status output.

Table 2. Absolute maximum ratings.

Supply Voltage, VCC	-0.3...+6V
Inputs voltage range EN_LI, BAT+, BAT-	0.3...VCC

Table 3. Recommended operating conditions.

Supply voltage, VCC	5V
Input voltage range EN_LI	3.3...5V
Input voltage range BAT+, BAT-	0...4.2V

Table 4. Electrical Characteristics.

	Minimum	Maximum	Units
Output current when charging Li, NiMH	0	1.0	A
Output current in En_li operation mode, supply of external circuit.	0	1.0	A
Input current, I_{in} , (Vcc=12V)	0	1.1	A
Input current EN	-	0.45	mA
Output current status, Li	-	40	mA
Current consumption when off	-	0.2	mA
Current consumption in Li-Ion mode	-	7.5	mA
Current consumption in charging mode	-	0.5	mA
Temperature mode	-40	+85°C	°C
Input voltage EN_Li, -low	0	0.6	V
Input voltage EN_Li, -High	2	VCC	V
Output Voltage when charging in progress Li-Ion, BAT+	4	4.2	V

	Minimum	Maximum	Units
Output Voltage, Status, low level (logical 0)	0	1	V
Output Voltage, Status, High level (logical 1)	3	VCC-0.3	V

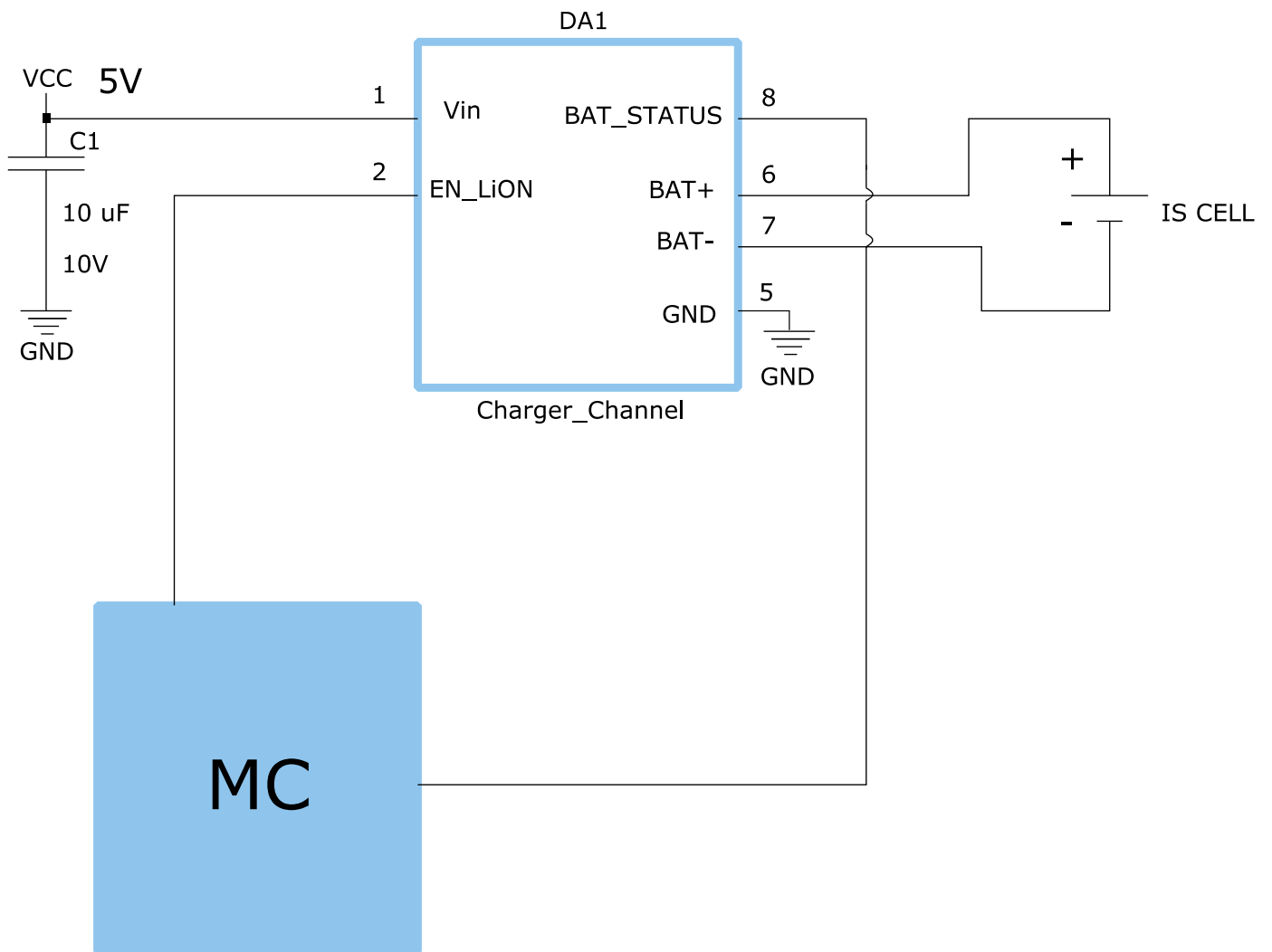

Pic.2. Connection scheme.

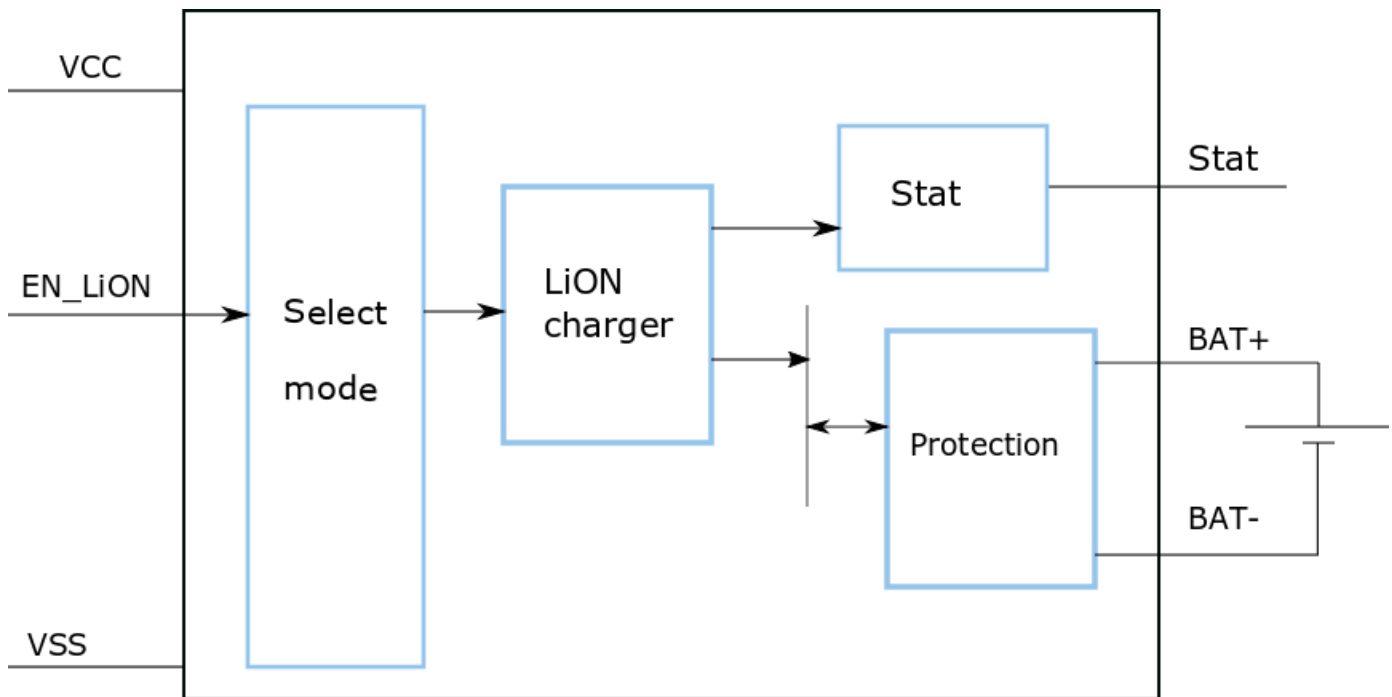

Pic.3. Main circuit nodes scheme ACM1803B.

Operation description ACM1803B.

Charge of Li-Ion Battery.

ACM1803B contains a charging unit for one Li-Ion or Li-Pol battery cell (then simply Li-Ion). The ACM1803B device can be used not only to charge batteries but also to power an external circuit (external voltage should be set to 4V). The charging process of the Li-Ion batteries divided into several steps. On each step of the charging the voltage outputs and inputs are monitored and controlled. If the supply voltage gets lower than 3.3V, the charge circuit enter in low consumption mode, the charging at this moment stops. The charging cycle starts if the supply voltage is correct, as well as the battery is present and in good condition.

The charging device has two main charging phases: precharge and main charge. The charging unit protected against exceeding battery voltage, temperature and short circuit. The precharging process takes place at the minimum current, until the moment the voltage of the battery is not within the permissible limits for the next stage of the charge. The precharging process allows the use the full capacity of the battery.

The main charge process divided into 3 stages: preparation, charge by direct current and charge by direct voltage, thus allowing reaching full charge fast and safely. When on preparation stage the nominal current value is raised until the nominal value as well as the voltage. From this point forward the current is being limited and the voltage is slowly dropping, at the end of the charge it reaches the minimum value. Which signals that it is the end of the charging process.

The precharge is limited by a timer to 30 min. The main charge is limited by a timer to 10 hours. If the timeout of 30 min or 10 hours is due then the charging process stops.

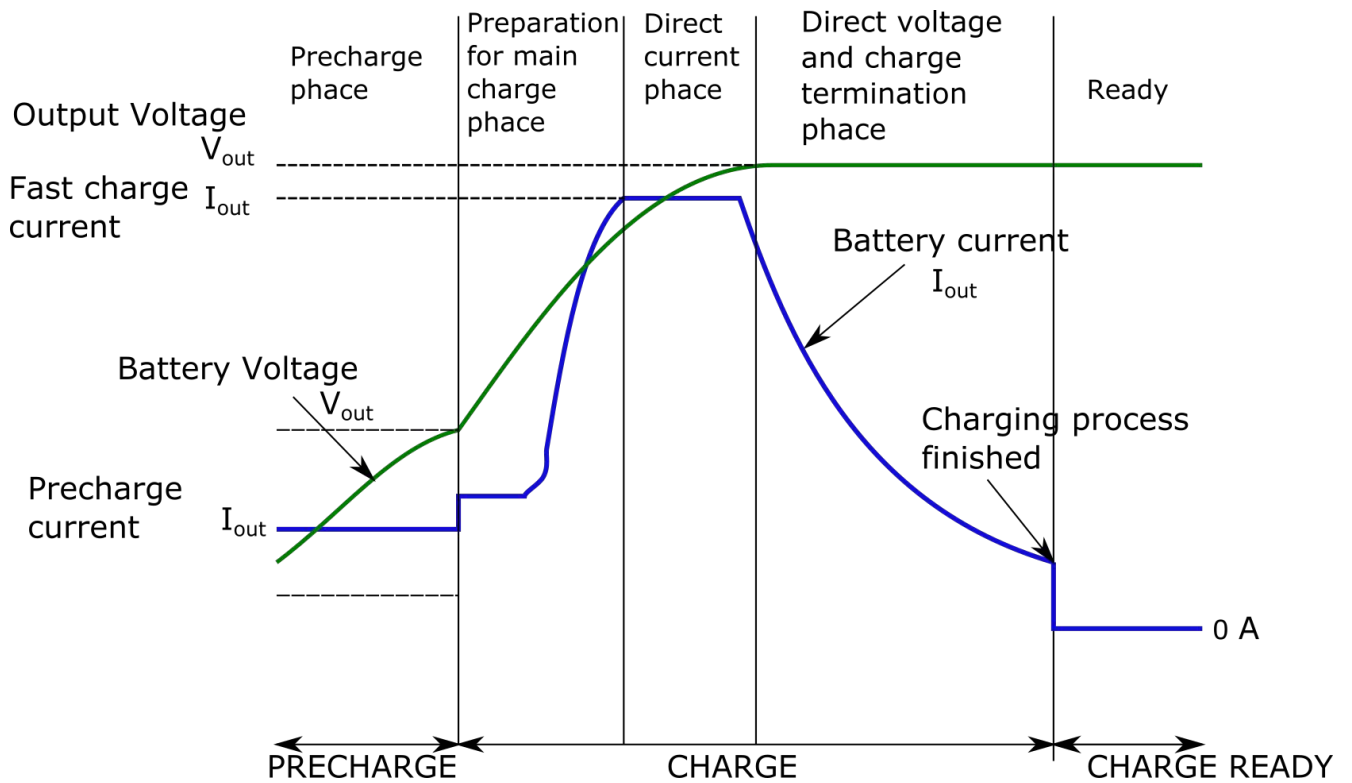

Pic.4 Charge profile of the Li-Ion battery.

To indicate the end of the charge the status output is used (BAT_STATUS). For this a LED needs to be connected to this output.

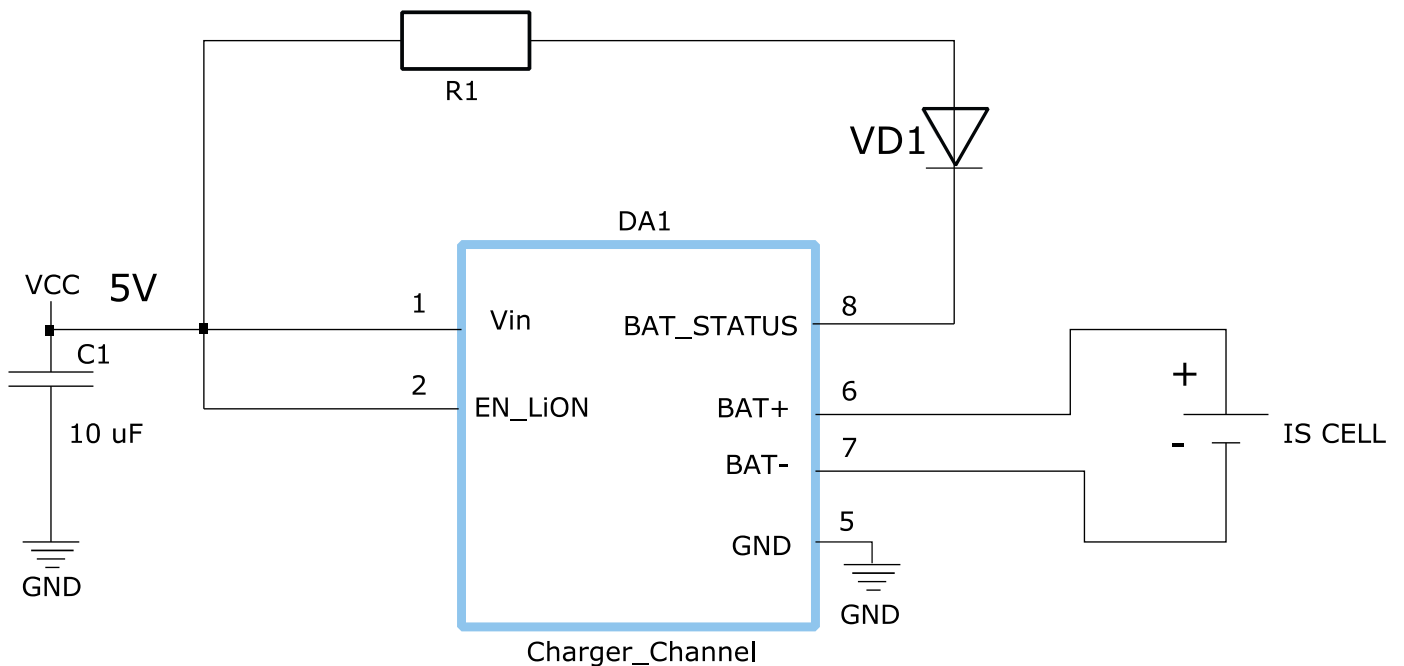

Pic 5. Use of STAT output for charge status.

Status

STATUS allows the indication of the current charge and battery state.

Table 5. Status in LI charge mode an external pull-up is required

	Charge status				
	No battery	Precharge	Fast charge	Sustain, powersave	Error
StatPIN	Log 1	Log 0	Log 0	Log 1	Log 1

Connection diagram

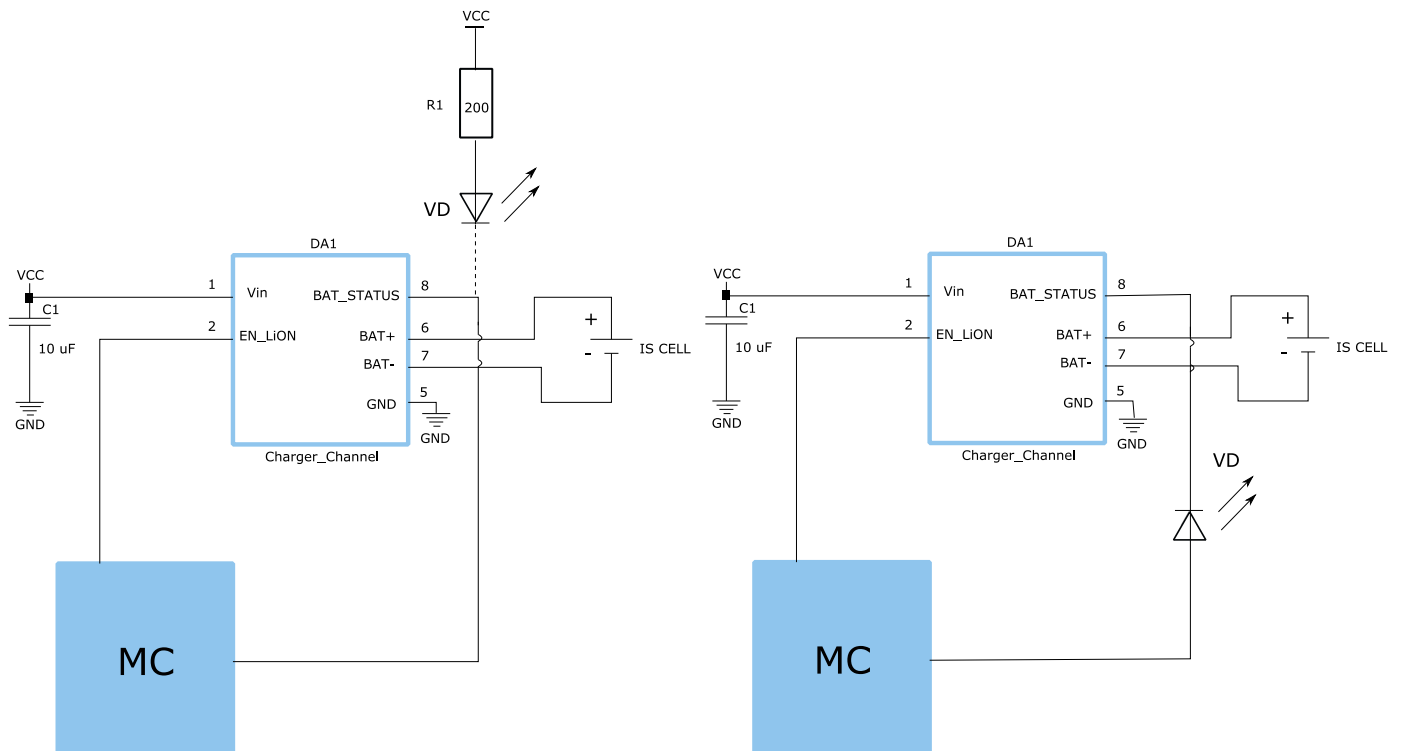

Pic. 6 Connection status "STAT" to LED

Protection

ACM1803B has implemented a battery protection from reverse polarity. If the battery is connected incorrectly then the current loss is less than 1uA.

Short circuit current while Li-Ion is operational (EN-Li - High Logical level) - not more than 130mA.

Dimensions and mounting seat.

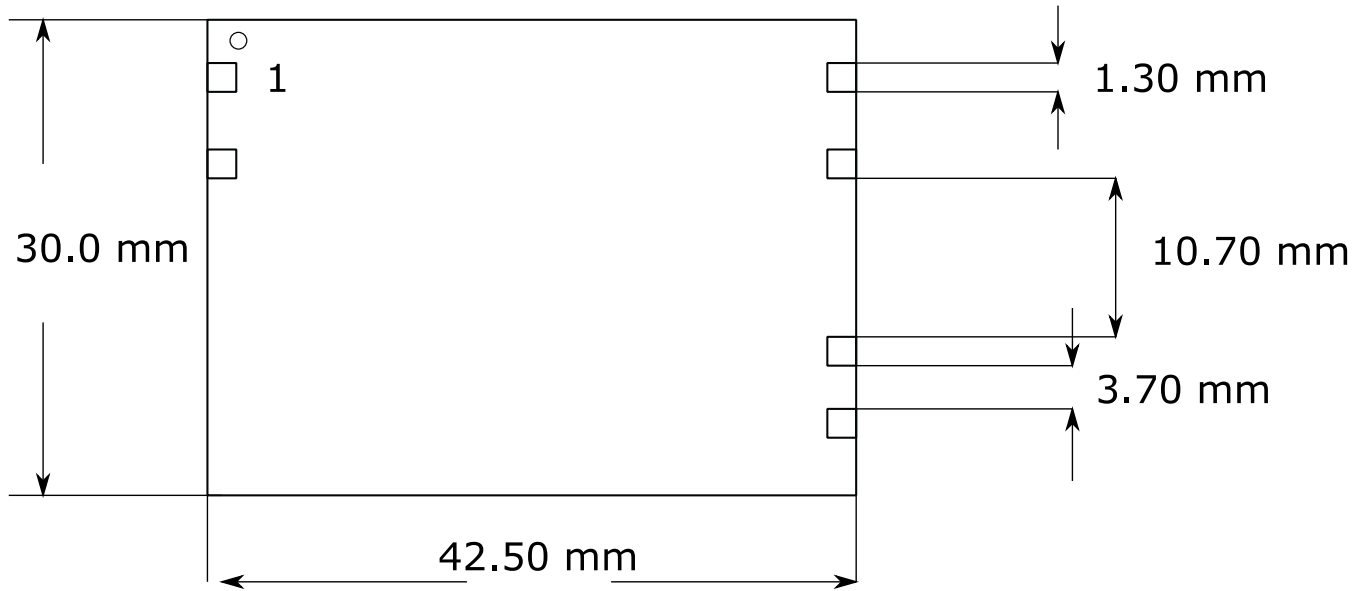

Pic. 7 Overall dimensions of the ACM1803B module.

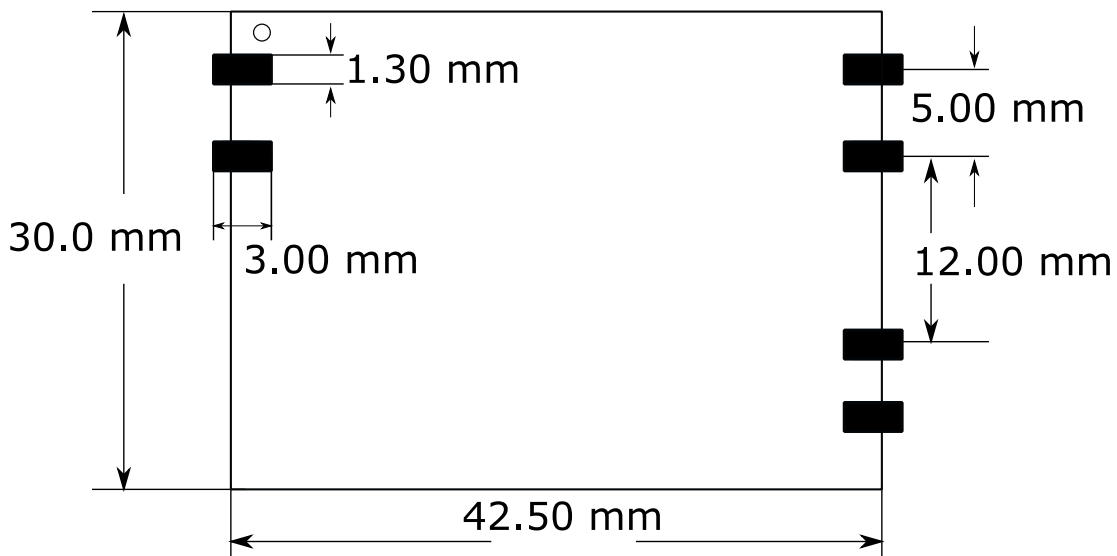

Pic. 8 Recommended mounting seat for ACM1803B module.