

Carest Charging module for rechargeable battery ACM1802E

The charging module is designed for charging and discharging single-cell nickel-metal hydride (NiMH) batteries.

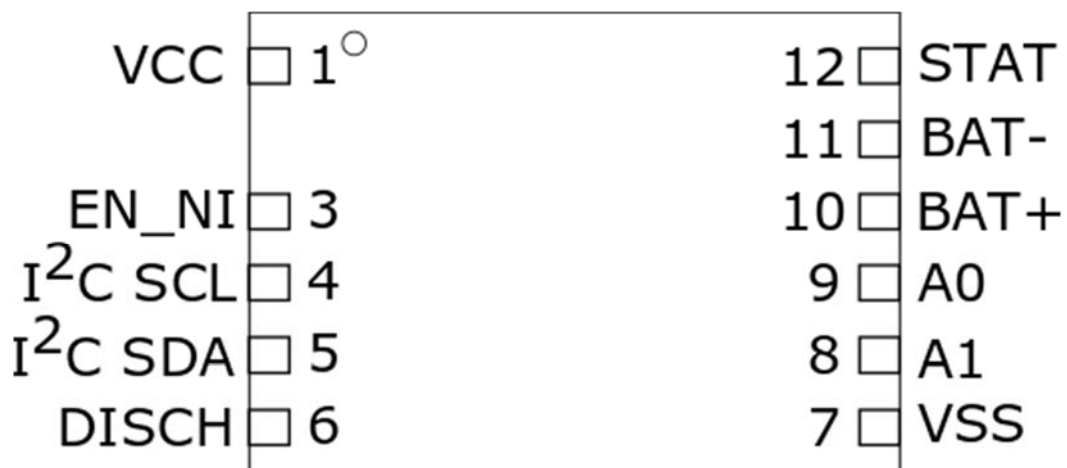

Pic.1 Schematic view ACM1802E.

Table 1. Contact overview ACM1802E:

PIN		Input/Output	Description
NAME	NUMBER		
VCC	1	Input	Supply voltage. Connects directly to the positive terminal of the charge source.
EN_NI	3	Input	Enable on the charging of the NiMH battery.
I ² C SCL	4	Input	I ² C Clock Input
I ² C SDA	5	I/O	I ² C Serial Data I/O Open Drain Output
DISCH	6	Input	Enable on of the discharge of the battery.
VSS	7	Input	GND. Connects directly to the negative terminal of the charge source.
A1	8	Input	I ² C Address 1

A0	9	Input	I ² C Address 0
BAT+	10	Input	Positive battery terminal.
BAT-	11	Input	Negative battery terminal.
STAT	12	Output	Charge status output.

Table 2. Absolute maximum ratings.

Supply Voltage, VCC	-0.3...+6V
Inputs voltage range EN_NI, DISCH, BAT+, BAT-, I ² C SCL, I ² C SDA A0, A1	0.3...VCC

Table 3. Recommended operating conditions.

Supply voltage, VCC	5V
Input voltage range EN_NI, DISCH	3.0...5V
Input voltage range BAT+, BAT-	0...4.2V

Table 4. Electrical Characteristics.

	Minimum	Maximum	Units
Output current when charging NiMH	0	0.5	A
Input current, I _{in}	0	0.55	A
Input current EN	-	0.45	mA
Input current Disch	-	0.3	mA
Output current status Ni	-	20	mA
Supply Current when off	-	0.2	mA
Supply Current in NiMH mode	-	1.5	mA
Supply Current in charging mode	-	0.5	mA
ΔV for NiMH	3		mV
Operation Temperature range	-40	+85°C	°C

	Minimum	Maximum	Units
Input voltage EN_NI - Low level	0	0.6	V
Input voltage EN_NI - High level	2	VCC	V
Output Voltage when charging in progress NiMH, BAT+	0	1.7	V
Output Voltage, Status, low level (logical 0)	0	1	V
Output Voltage, Status, High level (logical 1)	3	VCC-0.3	V
High Voltage Input, EN_Ni, DISH, A0, A1	$0.7 * VCC$	VCC	V
Low Voltage Input, EN_Ni, DISH, A0, A1	0	$0.3 * VCC$	V
I ² C SCL, I ² C SDA	0	3.3	V

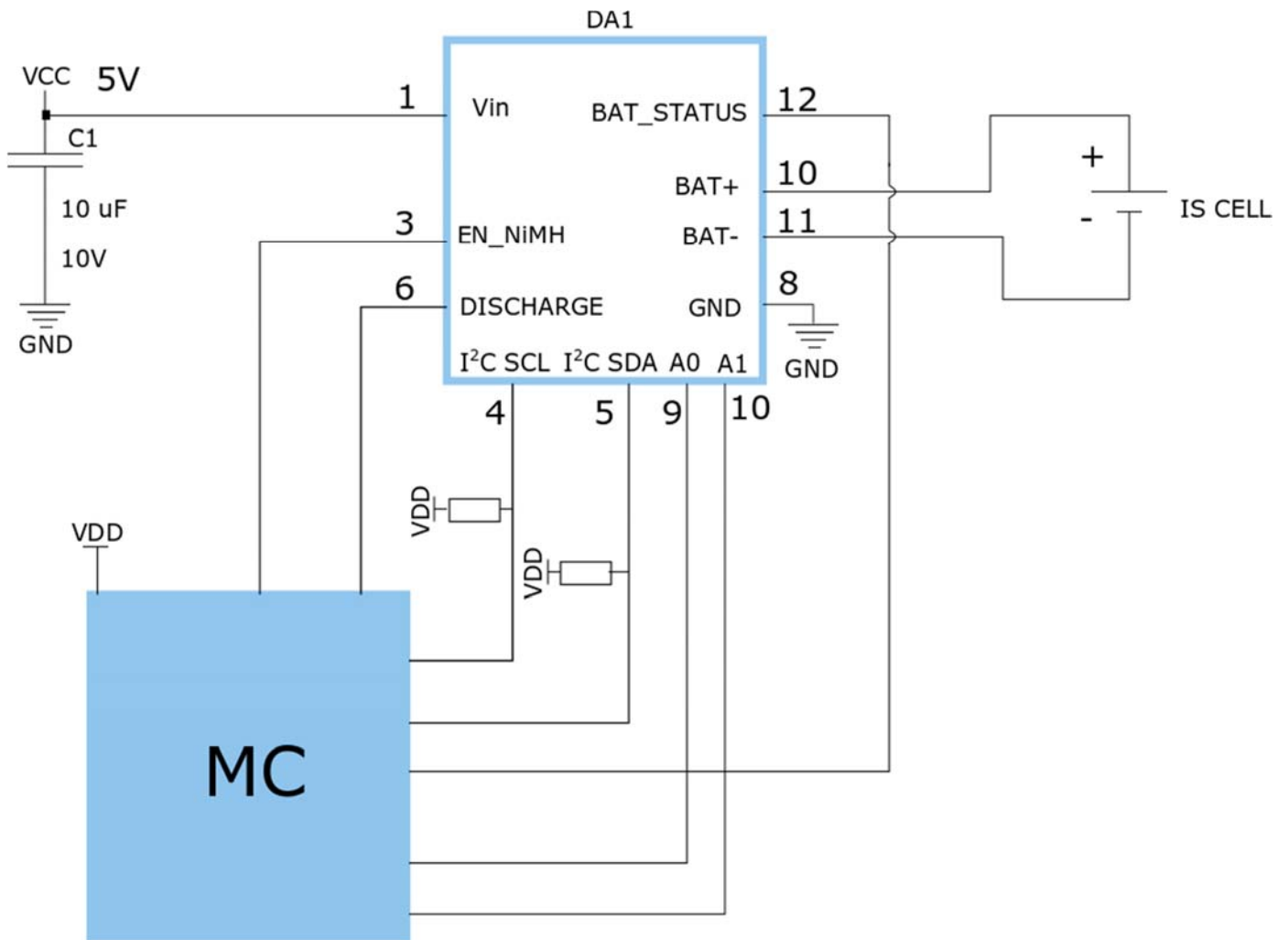

Pic.2. Connection scheme.

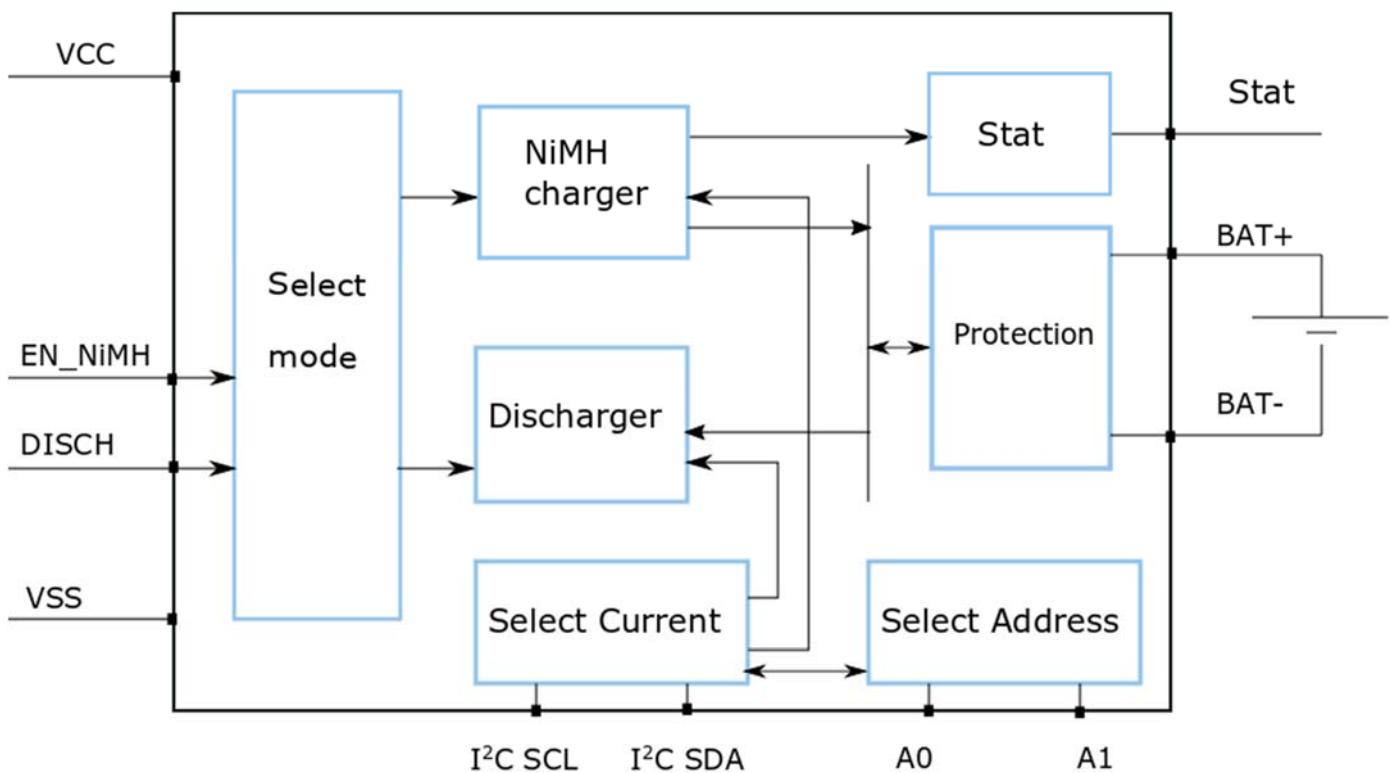

Pic.3. Main circuit nodes scheme ACM1802E.

Operation description ACM1802E

Charge of NiMH battery

ACM1802E implements an impulse charge algorithm. It is important to note that before turning on the charging module (EN_Ni in high state), the battery must be inserted.

The ACM1802E has several charging phases for NiMH batteries: "Precharge", "Fast charge", "Final charge" and "Saving".

When the battery is inserted, located by the device and its supply voltage is in the correct threshold, the ACM1802E goes into "Precharge" mode and starts testing the battery. This allows to prevent the "Fast charge" of old depleted batteries. The precharge process is set for a low speed charge until the cell reaches 1V. ACM1802E precharges the battery while regulating the voltage descend with a sensitive resistor up to 113mV. The device charges in impulse mode, the voltage is supplied to the battery 25% of all the time. All the other time the battery is disconnected from the power supply and it's voltage is measured. The STAT output while in "Precharge" signals the current charge state with a rectangular voltage, with 1Hz frequency. If the voltage of the cell is higher than 1V during 30 minutes then the ACM1802E goes into the "Error" state. If the ACM1802E is in "Precharge" state and is detected that the battery charge is higher than 1,75V then the device determines that the cell was extracted or is defective and enters in "Error" state. On the pic.6 is presented the operation chart of the switching on the internal generator.

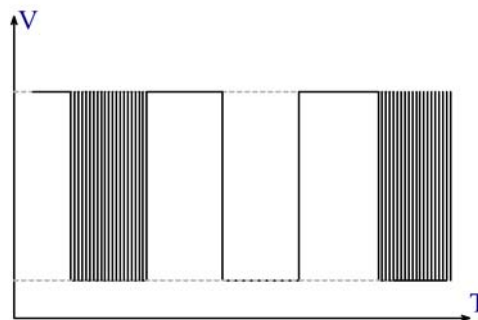

Pic.4. Operation mode "Precharge".

After this the ACM1802E switches to "Fast charge", which includes testing the battery to exclude charging by mistake an alkaline element or NiMH elements that are worn out or damaged. Fast charging continues as long as all battery health criteria are met. The fast charge ends on $-\Delta V$ method (negative delta voltage) - the voltage on the battery gets decreased when the battery charge is full. When the device is in "Fast charge" mode it regulates the voltage on the measurement resistor up to 113 mV.

On the STAT output is set a high voltage. In "Fast charge" mode the device tests the battery every 31 sec. by checking the external voltage from the battery with it's internal resistance and voltage. This measurements are compared with the previous values. The maximum cell voltage while charging is saved. If the cell voltage falls more than 3 mV ($V-\Delta V$) from it's maximum value, then the "Fast charge" is finalized and it switches to "Final charge" mode.

ACM1802E also switches to “Final charge” mode if the battery voltage doesn’t go over the maximum value for 16 minutes. The voltage of a separate battery is compared with a charged battery voltage. The difference is compared with the impedance threshold. If the difference is higher than the threshold value then the cell impedance is considered to be too high to charge and the ACM1802E switches to “Error” status. As an additional protection from overcharging ACM1802E ends “Fast charge” mode and switches to “Final charge” after 2,5 hours. If at anytime in “Fast charge” the voltage on the battery goes over 1,75V, the ACM1802E determines that the cell is either overcharged or was extracted and switches to “Error” status. On pic.5 is presented the operation chart of the internal generator in “Fast charge” mode.

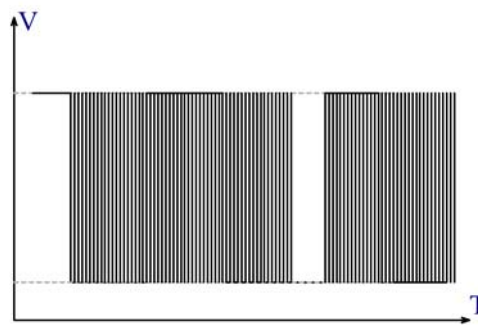

Pic.5 “Fast charge” operation mode.

For a full charge the “Final charge” phase is used. In this state the ACM1802E charges the battery with impulses with 25% of the speed of “Fast charge”. While charging the ACM1802E monitors the charge and the maximum battery voltage. If an error occurs while charging the ACM1802E switches to “Error” state and the charging process stops.

STAT output is off. The cell charge is maintained for an indefinite period by continuing to charge the battery by impulses with a duty-cycle of 1.56% of the total charge time. On pic.6 is presented with an operation chart of the internal generator.

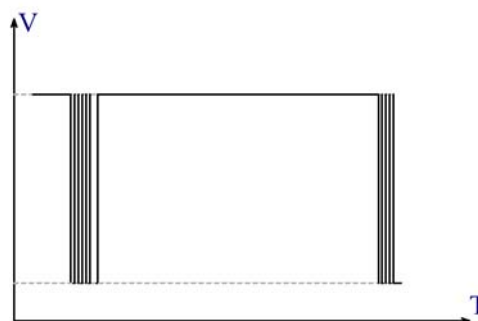

Pic. 6 Operation mode “Powersave”

In “Error” state, charging is switched off to avoid ruining the battery, on the STAT output a 4 Hz signal is given.

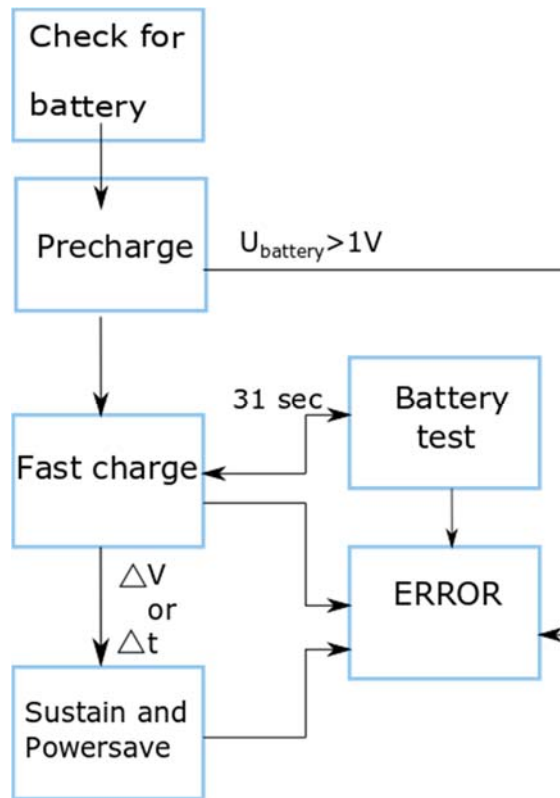

Pic.7 NiMH charging algorithm.

Status

STATUS allows the indication of the current charge and battery state.

Table 6. Status in NiMH charge mode

	Charge status				
	No battery	Precharge	Fast charge	Sustain, powersave	Error
StatPIN	Log 0	Charge with 1Hz frequency (50% charge)	Log 1	Log 0	Charge with 4Hz frequency (50% charge)

Connection diagram

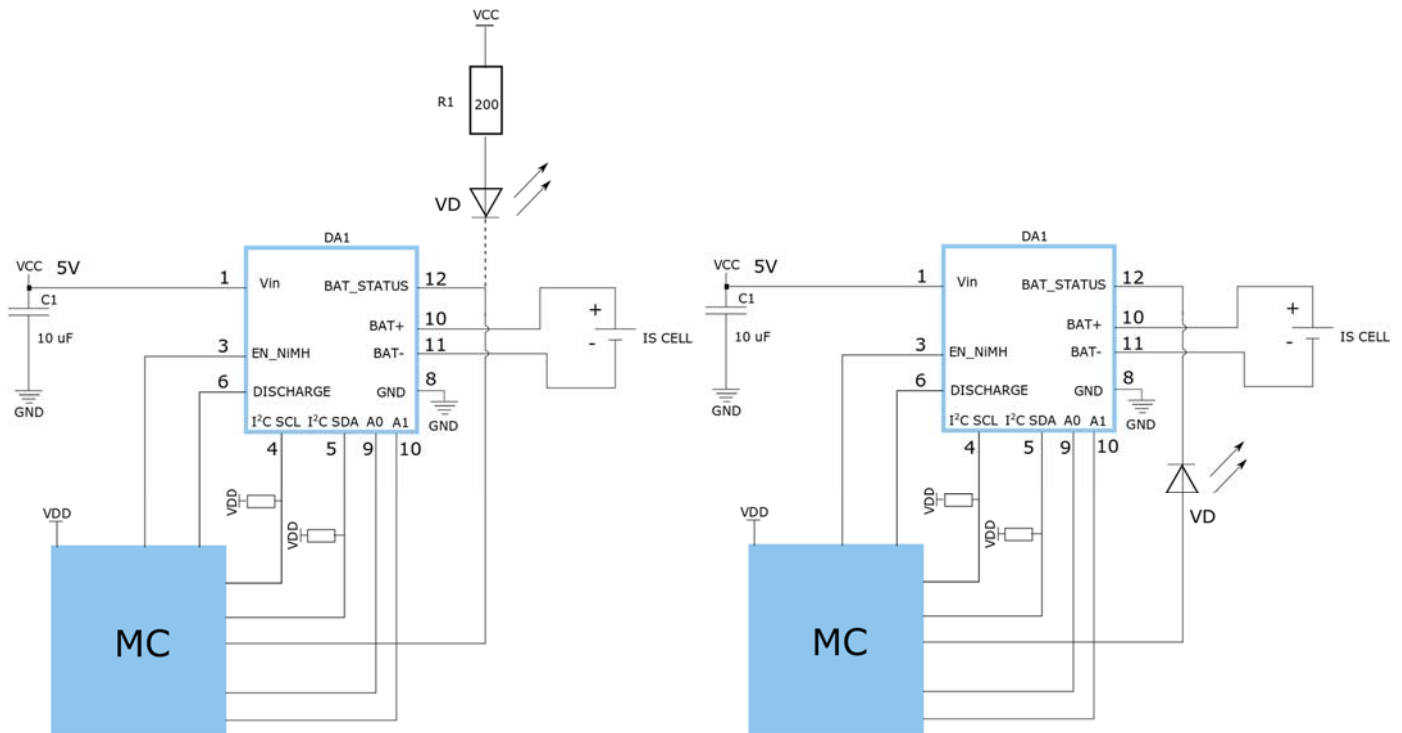

Pic. 8 Connection status "STAT" to LED

Protection

ACM1802E has implemented a battery protection from reverse polarity. If the battery is connected incorrectly then the current loss is less than 1uA.

Short circuit current while NiMH is operation (EN_NI - High Logical level) - not more than 1A during 0,5 sec (impulse detection of battery failure).

Dimensions and mounting seat

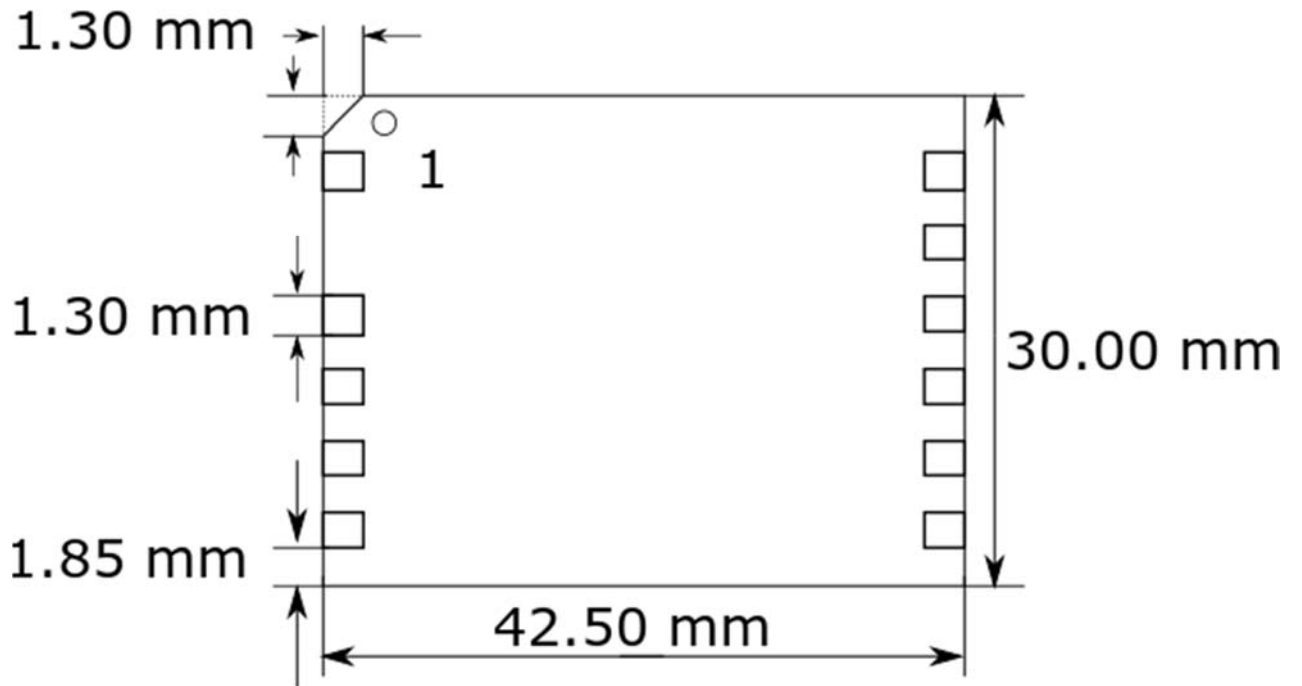

Pic. 9 Overall dimensions of the ACM1802E module.

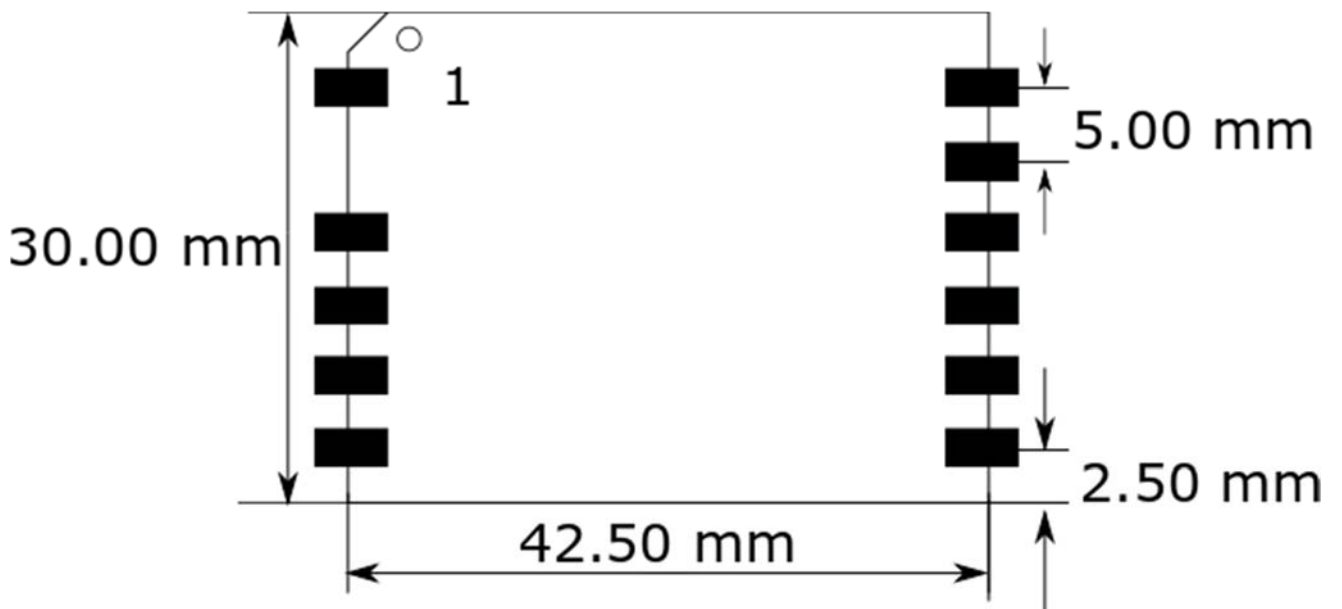

Pic. 10 Recommended mounting seat for ACM1802E module.